

EE 508 Laboratory Experiment 3

Effects of Op Amp Bandwidth and SR on Filter Structures

Due Tuesday October 11

Introduction: The active device in a filter structure generally plays a key role in determining or limiting the performance of the filter. In high-frequency filters the active device is often a transconductance amplifier or a single transistor whereas the active device in lower-frequency filters is often an operational amplifier. Regardless of whether operating at low frequencies or high frequencies, high-frequency limitations of the active devices invariably dominate the performance degradation of the filter. In filters employing operational amplifiers as the active devices, the finite gain-bandwidth product (GB) of the op amp limits the frequency domain performance of the filter.

Purpose: The purpose of this experiment is to investigate the effects of the amplifier bandwidth (specifically the GB) on the performance of filters. The effects of SR will also be considered. In this experiment, use the LM358A operational amplifier and assume it is biased with $\pm 15\text{V}$ supplies. Characteristics of the operational amplifier should be obtained from the data sheet (Use the Texas Instruments Data Sheet so that all have the same datasheet information).

Question: What is the cost of this op amp in unit quantities and on a tape/reel in quantities of 2500?

Experiment:

- a) Design a second-order resonator bandpass filter with a nominal pole Q of 10 to operate with a band-center (i.e. peak frequency) of ω_0 at 1% of the GB of the specified operational amplifier. The bandpass resonator structure is shown below. (This is alternatively termed a two-integrator-loop filter or the Tow-Thomas Biquad). In this design, assume the operational amplifier is ideal. **In this design, use component values that are available that are close to your design values. Then accurately measure the component values and use the measured values of the components in the remainder of this experiment. This will circumvent the need for trimming the filter structure.**

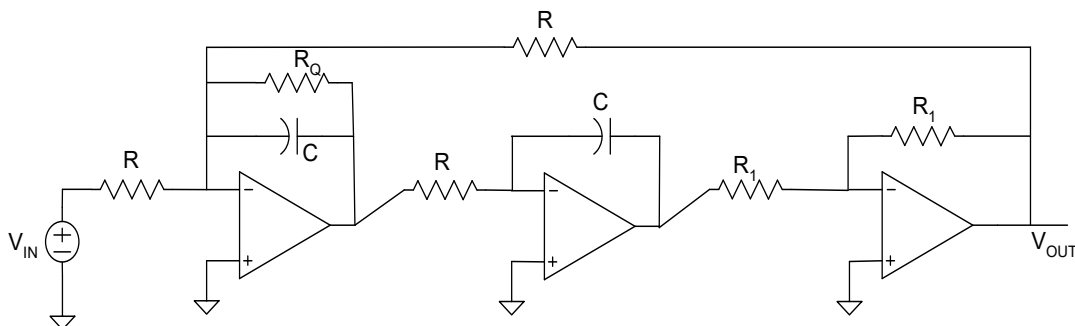

Second-Order Resonator Bandpass Filter

- b) Accurately simulate the magnitude of the transfer function and from this simulation determine the peak frequency and the two 3dB band edges assuming the op amps are ideal and compare the corresponding simulated peak frequency and bandwidth with the theoretical bandwidth.
- c) Develop a macromodel of the specified operational amplifier that includes the finite gain of the op amp and the finite GB of the op amp as obtained from the datasheet. (This is a single-pole model of the op amp.) Everything else in your op amp macromodel should be ideal.
- d) Using SPECTRE, simulate the frequency response of the filter using the single-pole macro model of the op amp developed in part c) and compare with that obtained in part b). How do the peak frequency and 3dB bandwidths compare?
- e) Increase the band edges of the filter by a factor of 4 doing frequency scaling of the passive components and compare the ideal response and the actual response. How does the bandwidth and simulated Q change when the frequency is scaled? Is this change expected?
- f) The manufacturer provides macromodels of the operational amplifier that include more effects than you were asked to include in the macromodel you developed in part c). Compare the results obtained in part d) with your macromodel with the results obtained from the macromodel obtained from the manufacturer.
- g) Consider again the design in Part a) but modify your macromodel (see Appendix 1) of the operational amplifiers so that the poles of the op amps are moved into the RHP but so that they are of the same magnitude and predict how the filter will perform. With this modification, are the op amps stable? Is the filter stable?
- h) Consider again the design in Part a). If the input is a sinusoid at the center frequency of the bandpass filter and the amplitude is adjusted so that the 0-p output amplitude is ideally 14V, will the filter output show any effects of the SR of the op amp? If the center frequency is increased by a factor of 10 by doing frequency scaling of the passive components, will the filter output show any effects of the SR of the op amp? Verify your conclusions using the macromodel of the operational amplifier that includes SR effects.
- i) If the input terminals of the middle operational amplifier are interchanged for the filter designed in part a), analytically calculate the transfer function of the filter if the gain of the op amp is very large. Simulate the magnitude of the transfer function with this modification. Simulate the transient response if the input is a sinusoid of peak amplitude 10mV and frequency of ω_0 of the filter. What conclusions can be drawn about interchanging the input terminal connections of the middle operational amplifier?

Appendix 1:

The standard single-pole model of the operational amplifier shown below is given by the standard expression

$$\frac{V_{OUT}}{V_A} = A(s) = \frac{A_0 \omega_A}{s + \omega_A}$$

where A_0 is the dc gain and ω_A is the 3dB bandwidth. In this model, A_0 and ω_A are both positive. The location of ω_A is set to the desired value during compensation to provide the desired phase margin.

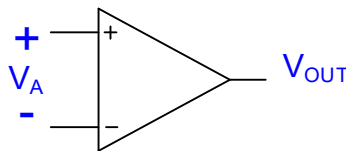

It is relatively easy when designing the operational amplifier to change the compensation strategy to obtain a modified transfer function given by the expression

$$\frac{V_{OUT}}{V_A} = A_{\text{mod}}(s) = \frac{A_0 \omega_A}{s - \omega_A}$$

where A_0 and ω_A are both positive as well. This latter gain is the modified gain referenced in part f).